

# WINE | Upright Cabinets

WINE COOLERS

CW 40



## DETAILS



## GENERAL FEATURES

- 100 Lt. Wine cellar with built-in installation
- External in black coated plate, black thermoformed internally
- Ventilated Cooling
- Automatic compressor cycle defrost
- Foaming Agent Cyclopentane (35mm per side)
- Digital display control
- Low energy consumption
- Removable Gasket
- Interior LED light (Blue Color)
- Reversible door with vertical cylindrical handle
- N.1 charcoal filter fitted as standard
- Opening door alarm
- Double layer safety tempered glass
- Tinted glass door for wine protection
- Adjustable wooden shelves (N.6 pcs)
- N.4 Adjustable feet
- Energy efficiency class: F

## TECHNICAL SPECIFICATIONS

Capacity	106 L
Temperature	+5° ~ +18°C
Consumption	0.274 kWh/24h
Rated Power	85 W
Noise level	39
Net Weight	35 Kg
Gross Weight	39.5 Kg
External Dimensions (WxDxH mm)	380x647x865
Internal Dimensions (WxDxH mm)	310x453x698
Packaging dimensions (WxDxH mm)	415x670x895
Loading quantities 20°/40°/40°/HQ	116/243/287

## PRODUCT DIMENSIONS

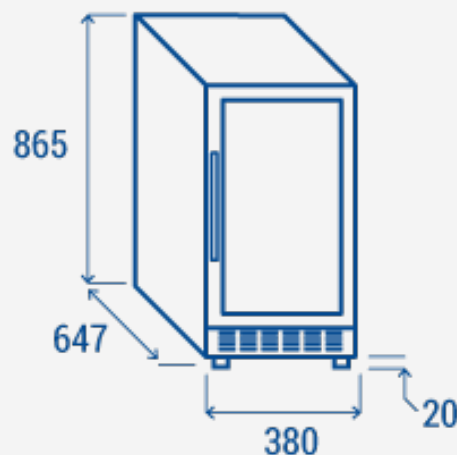

## CERTIFICATION

CE RoHS



COOL HEAD EUROPE  
We make the world a cooler place



www.coolheadeurope.com